

Van Steenburgh
Refrigerant Recovery System
RV Series



Operations Manual

Contents

Introduction	
Purpose	1
General	1
Operation Recap	4
Getting Started	
Set Up Procedures	4
Operating Characteristics	4
Hints	5
Operation	
Recovery Operation	6
Pump Out	7
Filter/Drier	7
Oil Out	7
Non Condensable Purge	8
Maintenance	
Changing Compressor Oil	8
Trouble Shooting	9
Specifications	10
Electrical Schematic	11
Flow Chart	13

Van Steenburgh
Engineering Laboratories, Inc.
1825 No. Lake Ave.
Estes Park, Co. 80517 U.S.A.

970/586-8412
Fax 970/586-8060

Introduction

Purpose

The Van Steenburgh Refrigerant Recovery Systems are used to recover specific refrigerants from a refrigeration or air conditioning system. They can also be used to remove or transfer refrigerants from cylinders.

General

The Van Steenburgh Refrigerant Recovery System is designed and constructed of top quality steel cabinetry and finished with bonded epoxy paint. All component parts are of the highest quality including all gauges, solenoids, valves, controls and switches. All parts are available direct from the manufacturer or from a Van Steenburgh Engineering distributor.

The equipment is designed with the technician and work place in mind. The gauges are laboratory quality to assure long life and excellent calibration. Switches are clearly marked and easily accessible on the front control panel.

Your Van Steenburgh System has been ruggedly constructed with your day-to-day activities in mind. All refrigerant carrying tubing is copper and the cabinet is reinforced for sturdiness.

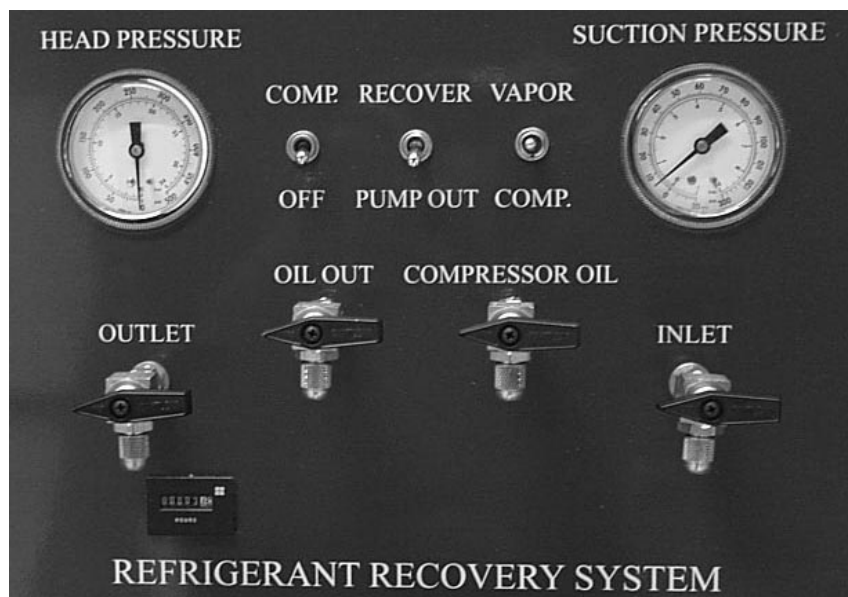



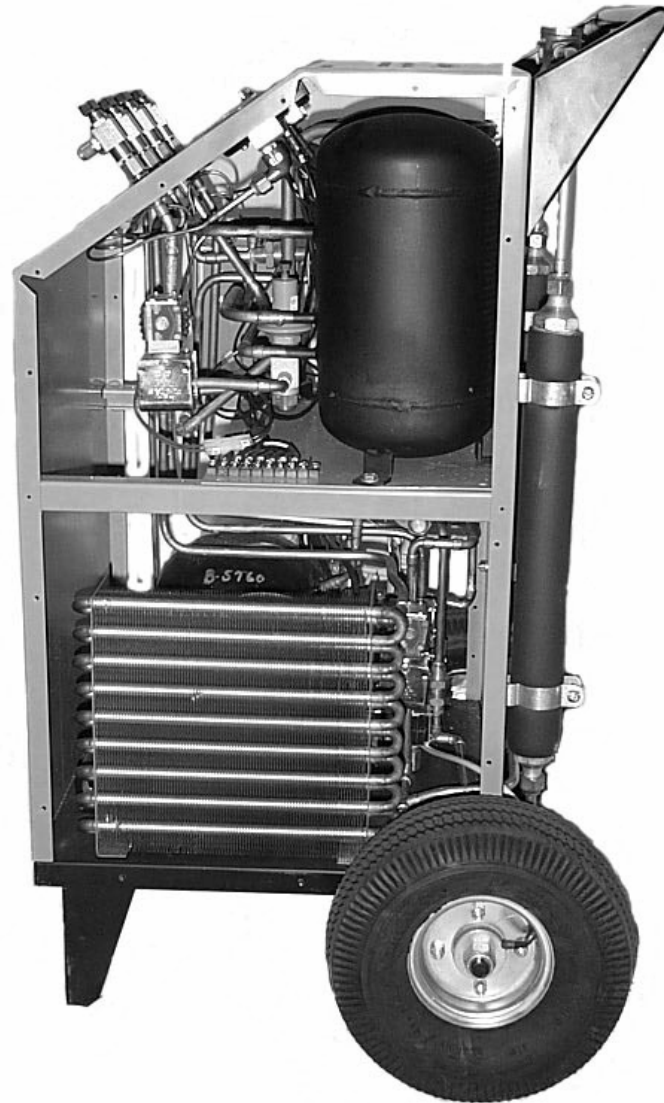

Operation Recap

1. Refrigerant can be taken into the system as EITHER vapor or liquid.
2. It is taken to high temperature and high velocity using the heat of compression and the heat from the compressor discharge.
3. It then enters a large unique SEPARATION CHAMBER where the velocity is reduced to near zero. During this phase, copper chips, carbon, oil, acid, water and all other contaminants drop to the bottom of the CHAMBER where they can be removed during the “oil out” operation. (This process also allows you to accurately determine the amount of oil removed from a system).
4. The super heated vapor, at high temperature, rises and passes from the SEPARATION CHAMBER.
5. The vapor then passes through the compressor to the air cooled condenser where it is converted to liquid.
6. Two replaceable driers in this circuit remove any remaining moisture, which may have gotten by the SEPARATION CHAMBER, before it is stored in the portable cylinder.

Getting Started

Set Up Procedures

Each system is thoroughly tested before it leaves the factory. At the completion of the test procedure each unit is pressurized with nitrogen to protect it during shipment. Your unit will have a tag on the front indicating same.

1. Make sure unit is connected to proper voltage.
2. Open INLET and OUTLET valves and allow system to come to atmospheric pressure. Hook vacuum pump to both INLET and OUTLET fittings, then turn compressor switch on. Pull a vacuum for approximately 5-7 minutes. The center switch must be in the RECOVER position.
3. You are now ready to accept refrigerant.

Operating Characteristics

The individual sections in this manual deal with the step by step action for the operating procedures. The following operating characteristics apply in general and should be taken into consideration.

1. All Van Steenburgh Recovery Systems are industrial grade equipment.

They are based on established sound heat transfer principles and depend, to an extent, on the refrigerant in the recovery system to achieve maximum performance. Consequently, you will achieve the best results if you follow some basic procedures.

1. When starting to reclaim LIQUID refrigerant, regulate pressure on suction gauge to 10-15 psi/.68-1 bar for 2-3 minutes. This simple warm up procedure will help considerably towards assuring smooth operation and clean refrigerant. This warm up gets the heat exchanger up to temperature and this will assure good “separation” as the refrigerant enters the Separation Chamber.
- B. The OIL OUT operation is especially important. By conducting frequent OIL OUT procedures you will keep the separated oil below the level of the chamber’s entry port and assure that the oil/moisture mix will not start foaming and re-entrain with the vapors.

Note: *Avoid using Extension Cord. It may overheat. If necessary to use cord, use shortest possible length of No. 12 AWG minimum.*

Hints

Long Hose Pulls

On occasion longer lengths of hose are required when it is not possible to get the Recovery System to the source. In these cases it is important to remember the following:

- A. Always use the largest diameter refrigerant hose possible - at least a 3/8".(10mm)
- B. The line loss will begin to have a more noticeable effect after 25 feet.(7.67m)
- C. At 50 feet /15 meters (75°f/22c) the liquid capacity will be reduced by 20 percent. The vapor capacity, however, will be diminished by 67 %.
- D. Pumping capacity will diminish drastically as hose lengths exceed 50 feet.(15meters)

Low Ambient Operations

The Recovery unit is no different from any other piece of equipment that depends on a compressor. The lower the ambient, the more important it is to assure the compressor is warm enough.

- A. Don't leave Recovery unit in a service truck overnight during cold weather. Leave it at a warm location.
- B. Low ambient temperatures will mean longer "pull times". Hooking into liquid side is even more important during these conditions.

Operation

Recover

1. Connect Recovery unit to proper voltage.
2. Attach hose to 1/4" flare fitting labeled inlet. Attach other end to the source and purge hose. Use a gauge at the source as this will show when source is empty.

Note: Hook up to liquid side whenever possible.

Removing liquid first is much faster. It also serves to cool the compressor motor in the recovery unit. Other reasons to hook to liquid side.

- A. Drawing vapor means you will be boiling the liquid without a heat source, which will drastically reduce the efficiency of the operation.
 - B. If there is refrigerant in the oil of the source compressor, it will cause oil to leave and enter the recycler.
3. Attach cable to recycle cylinder and one end of hose to 1/4" flare fitting labeled outlet. Attach other end of hose to vapor port on cylinder.
 4. Turn compressor switch and recover switch on and open inlet valve. If recovering liquid regulate suction gauge pressure to 10-15(.68-1bar) psi for 2-3 minutes before opening valve fully.
 5. Open outlet valve and purge hose. Open vapor valve on recovery cylinder.

Note: If recovery cylinder fills before source is empty the float in the cylinder will close the inlet solenoid and the unit will pump down and shut off.

Close outlet valve and vapor valve on the cylinder. Disconnect hose and replace cylinder.

Be sure to perform oil out procedure frequently during recycle operation.

6. When source is empty of liquid, turn vapor switch on. Leave on until source and recovery unit have equalized at 3-4 psi (.2-.3bar). When equalized turn vapor switch off and unit will pump down to approximately 5"(.03386 bar) vacuum. If additional vacuum is required use the compressor momentary switch.

Note: With the VAPOR switch turned on, the liquid injection valve will activate when the suction gauge gets down to 3-4 psi (.2-.3 bar) and cool the compressor motor.

Pump Out

To clear unit close inlet valve, compressor switch on, center switch to pump out and vapor switch on and outlet valve open. Unit will pump down to 5"(.03386 bar) vacuum and shut off. Turn compressor off and use the compressor momentary switch to pull recovery unit to required vacuum. Then close outlet, put center switch to recycle with vapor switch on. Unit will then equalize.

If positive pressure remains after equalizing, repeat pump out procedure.

Note: If switching refrigerants after pump out operation it is recommended to pull a vacuum on Recovery unit with a vacuum pump.

Filter/Drier

A moisture indicator sight glass is provided in series between the two filter/drier towers so drier performance can be monitored. Unit must be at "0" psi before changing towers.

Oil Out

Turn off inlet and let unit pump down and shut off. Turn compressor switch off and by using the reclaim/pump out switch add 2-3 psi (.1-.2bar) to suction gauge. Do this by flipping switch to pump out position and returning to reclaim position. Put a container under the oil out valve and slowly open valve. When oil quits draining close valve.

Non Condensable Purge Procedure

Use the following procedure to check for non condensables and for purging.

1. Put magnetic thermometer on refrigerant cylinder.
2. Put gauge on vapor port of cylinder.
3. Compare gauge pressure with target pressure on thermometer. If gauge pressure is more than 5 psi (.3447 bar) of target pressure purge vapor for 15 seconds.

Wait 3 minutes and make comparison again.

Repeat step 3 until gauge pressure and target pressure on thermometer are within 5 psi of each other.

Maintenance

Compressor Oil

This unit is equipped with a discharge line oil separator. This separator removes any oil that might leave the compressor and returns it by means of a capillary tube. The oil should be changed after every **100 hours** of operation.

Removing Compressor Oil

1. Locate the valve on the front of unit labeled Comp. Oil.
2. Attach one end of hose to fitting and other end to an empty container.
3. Hold compressor momentary switch down until suction gauge reads "0" with the Recover/Pump Out switch in the Recover Position.
4. Put 3 psi (.2 bar) on the suction gauge by flipping Recover/Pump Out switch to Pump Out. Do not exceed 3 psi (.2 bar). Open Comp. Oil valve on front panel and tilt unit slightly to the front. When oil quits draining close Comp. Oil Valve.

Adding Compressor Oil

1. After all oil is removed the compressor should be recharged with **7 oz. (200cc)** of **Mobil Artic EAL 22** compressor oil.

2. Hold compressor momentary switch down until a small vacuum is indicated on suction gauge.
3. Attach one end of hose to Comp. Oil fitting and other end to oil supply.
4. By opening Comp. Oil valve oil will be pulled into compressor. DO NOT OVERCHARGE

Troubleshooting

Problem

Solution

Unit won't accept refrigerant

1. Check inlet ball valve
2. Check that cable is attached to recycle cylinder.
3. Make sure recycle cylinder is not full.
4. Check valves in hoses.

System "Pulls Slowly"

1. Check to assure you are hooked to liquid side of source.
2. Low ambient temperature, apply heat to source.
3. Check hoses for restrictions.
4. Connecting hose to source too long.

Oil in lines

1. Oil out operation has not been completed on a regular basis. Separator chamber is full and oil has migrated through system.

Specifications

Model RV-220

Dimensions

Width 20 in. / 50.8 cm

Depth 23.5 in. / 99.7 cm

Height 33 in. / 83.8 cm

Weight

98 lbs. / 44.5 kg (approx.)

Compressor

.50 Horsepower

positive displacement hermetic

Electrical

120/1/60

220/1/50 Export

Refrigerants

R12, R134a, R401C, R406A, R500, R401A, R409A,
R401B, R412A, R411A, R407D, R-22, R411B,
R-502, R407C, R402B, R408A and R509

In/Out Valves

1/4 in. / 6.3 mm SAE Flare

Storage Capacity

30 lb / 13.6 kg in remote cylinder

Recovery Capacity

1.2 lb / .5 kg per minute liquid
vapor slightly less

UL Approved

Meets all EPA requirements

120/1/60

